

# McBerns Pty Ltd Vent Odour Filters

## McBerns Sewer Vent Odour Filters

The **McBerns Odour Filters** are not a mask they absorb & treat all noxious odours and biogases including hydrogen sulfide by a continuous process, where the specially formulated media captures the sulphide gas (H<sub>2</sub>S) & other foul odours and neutralises them by changing the molecular structure. Thus only releasing clean air into the environment. The filters are designed to fit 50mm, 100mm, 150mm and 300mm sewer vent pipes and can be adapted to any pipe dimension.

The filter media consists of various grades of an absorbent natural mineral and carbon combined with a very small quantity of an oxidising chemical. Safe to handle and easily installed, replacement media cartridges are available for the VF100, VF150 and VF300 Filters. The housing is constructed of UV resistant PVC to last many years exposed to the elements and sewer conditions.



VF100 Vent Filter



VF300 Vent Filter



VF50

VF100

VF150

### Filter Dimensions

Filter Model	A(ID)	B	C	Weight
VF50	55mm	130mm	90mm	230gms
VF100	110mm	120mm	165mm	820gms
VF150	160mm	190mm	250mm	2355gms
VF300	300mm	430mm	400mm	12kgs

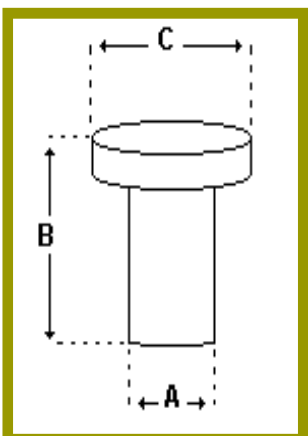

ABN 56 060 984 107

## McBerns Pty Ltd

ODOUR AND INFRASTRUCTURE MAINTENANCE MANAGEMENT

69 Running Creek Rd

PO Box 304 Yandina Qld Australia 4561

PH: 61 7 5446 7167 FAX: 61 7 5446 7162

mail@mcbarns.com

©McBerns Pty Ltd 2006 Updated 13/02/10

[www.mcbarns.com](http://www.mcbarns.com)

# McBerns Vent Odour Filters with Extractor Fans

## McBerns Sewer Vent Odour Filters

The **McBerns Odour Filter Range** has gone one step further making our **Vent Odour Filter** even more effective in absorbing all **foul odours including hydrogen sulfide**, by adding an Extraction Fan to the VF100, VF150 and VF300 filters.

The addition of the wind driven fan assists in the extraction of the foul odours from pump stations and surrounding buildings, sewer lines or confined spaces.

**Replacement media cartridges** are available for the VF100, VF150 and VF300 versions when the filter media reaches saturation. Safe and easy to install and recharge.

The **McBerns Odour Filters** are constructed of UV & chemical resistant PVC and the Extractor Fans are manufactured from 5005 Grade aluminum and powder coated inside & out, to withstand the harsh sewerage environment.

**Once you install our filters  
customer complaints will disappear!**

**For an Instant and Cost Effective Removal  
of noxious, corrosive & foul smelling  
gases install a McBerns Vent Filter .**



VF300 with Extraction Fan  
on Pump Station Building

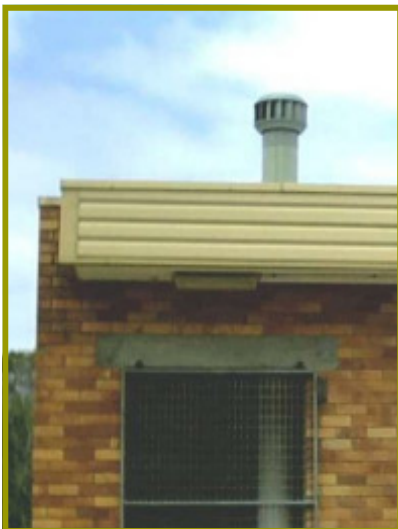

VF300 with Extraction Fan  
on Pump Station Building



VF300 Stack with  
Extraction Fan



VF100 with Extraction Fan



VF300 with Extraction Fan